

MANUAL
for
VIBRAMETER TYPE IV
2014.07.18



SBMEDIC Electronics

Schultzvägen 39
S-170 63 Solna, SWEDEN
phone: Int+46 8 356827, fax: Int+46 8 356874
e-mail: info@sbmedic.se
www.sbmedic.se



TABLE OF CONTENTS

Chapter 1.	INSTALLATION	
1.1	Unpacking	Page 2
1.2	Mains supply	2
1.3	Testing	3
Chapter 2.	OPERATING INSTRUCTIONS	
2.1	Before measurements	5
2.2	Measuring procedure	5-6
Chapter 3.	USE OF NORMAL MATERIAL	
3.1	Description of different tables	7
Chapter 4.	NORMAL TABLES	
4.1	Short description	8
4.2	Carpal VT	9
4.3	Tibial VT	10
4.4	Tarsal VT	11
4.5	Carpal VPT	12
4.6	Tibial VPT	13
4.7	Tarsal VPT	14
Chapter 5.	CONSTRUCTION OF NORMAL TABLES	
5.1	Statistical procedures	15
Chapter 6.	MEDICAL BACKGROUND	
6.1	Different diseases	16
6.2	Determination of vibration sense	16
6.3	The measuring instrument	16
Chapter 7.	GENERAL DESCRIPTION OF VIBRAMETRY	
7.1	Development of the technique	17
7.2	The VIBRAMETER	17
Chapter 8.	TECHNICAL DESCRIPTION	
8.1	Function	18
Chapter 9.	TECHNICAL DATA	
9.1	Data sheet	19
Chapter 10.	SERVICE AND REPAIR	
10.1	During warranty	20
10.2	Calibration	20
10.3	Warranty	20
Chapter 11.	IMPORTANT INFORMATION ON RECYCLING OF ELECTRONIC EQUIPMENT	
11.1	EU-countries	14
11.2	Countries outside the EU	14

CHAPTER 1. INSTALLATION

1.1 UNPACKING YOUR NEW VIBRAMETER

- a/ First inspect the package for external signs of transport damage. If any sign of damage is noted, please notify us as soon as possible.
- b/ When unpacking the VIBRAMETER, handle the Vibrator (with a long cable, ending with a connector) carefully.
- c/ Save all packaging material ! You will need it when returning the instrument for free calibration, included in warranty.
- d/ When unpacked, check the VIBRAMETER and Vibrator for any external signs of transport damage (ref a/, above), then perform a functional test, carried out by following chapter 1.2 and 1.3
- e/ Before using the VIBRAMETER for evaluation of sensory dysfunction, we recommend You to study chapter 2, and if You intend to use a normal material as reference also paragraph 4.
- f/ To obtain the full 1 year warranty, with free calibration services, You need to return the warranty registration card. Read paragraph 12.
- g/ If You at this point have any questions regarding the function of the VIBRAMETER, or its operation, we recommend You to carefully read the rest of this manual and to contact us, or our representative, to clear out any questions that may remain. Our address is found on the front page.

1.2 MAINS SUPPLY

- a / Make sure that the available mains supply corresponds with the voltage indicated on the mains connector (ref. Fig. 1). The arrow indicates the setting of the voltage selector. To change the setting, the part of the mains connector, with the arrow indicator and a “picture” of a fuse (ref. Fig. 1b), should be removed. For this, a screwdriver is inserted in the small oblong hole, as indicated in Fig. 1, just below the arrow indicator.

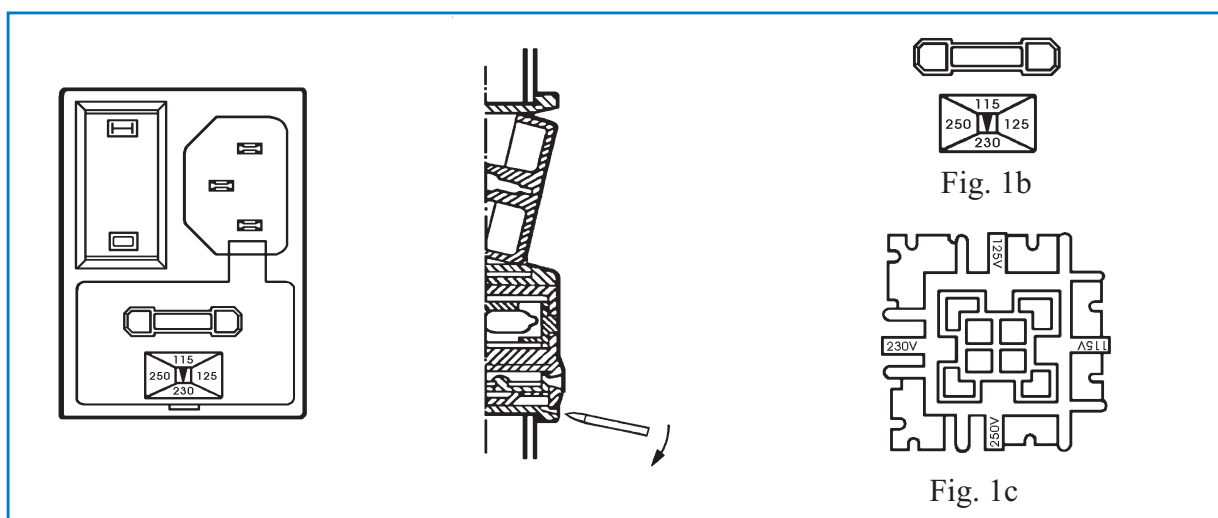

Fig.1

With a slight bending action the part can be removed, and access is given to the fuses and the voltage selector module (ref. Fig. 1c). To change the voltage, the voltage selector

module should be removed from the part, and again inserted so that the arrow points on the new setting. At the same time the fuses should be changed to: 160mA at 220V or 320mA at 110V, in both cases slow blow fuses.





1.3 TESTING

- a/ Connect the Vibrator to the connector at the back of the control unit.
- b/ Connect the mains supply, using the cord delivered with the VIBRAMETER.
- c/ Switch the power switch at the back of the control unit to ON. Note that an indicator in the power switch, as well as a red dot at the front panel, becomes illuminated.
- d/ On the front panel of the VIBRAMETER there are two groups of pushbuttons, and one thumb wheel, according to Fig. 2. Press the button marked **I** and the digital display will be illuminated.



Fig.2

- e/ Hold the vibrator of the VIBRAMETER in Your right hand and let the probe rest against a flat surface. Push with Your left hand simultaneously the buttons **C** and **W** . Note that the red dot on the “thermometer” scale moves to the middle, and release thereafter the buttons **C** and **W** . When the dot is in the center of the scale, the application pressure will correspond to the weight of the vibrator. (approx. 650 g)
- f/ Move Your left hand to the group of eight pushbuttons, at the left side of the front panel, and check that the decimal point in the digital display jumps between one and two decimal places when pressing button **R** . This button changes the measuring range of the VIBRAMETER between 39.99 microns and 399.9 microns full scale.

- g/ Also observe that pressing  button illuminates the text **HOLD** under the digital display. This indicates that the measured value is held in the digital display and can be read at a later moment. A second press on  returns the VIBRAMETER to normal measuring mode.
- h/ The vibration amplitude of the probe is controlled with the pushbuttons marked with arrows, or with the thumb wheel. An up-arrow indicates increase and a down-arrow decrease of the vibration amplitude. A fat arrow  indicates a rapid change of the vibration amplitude, a thin  arrow indicates a slower rate of change. To simplify the operation of the VIBRAMETER the layout of the pushbuttons has been set so that the left hand of the operator can rest on the front panel while the different pushbuttons can be reached with the fingers.

An alternative is to use the thumb wheel found immediately to the right of the push-buttons. Moving it up increases the amplitude, moving it down decreases it. This facility will prove to be very handy in quick searches for sensory thresholds, after which a more accurate determination can be performed starting at the approximate level found by the thumb wheel. In any case, when the amplitude increases an indicator to the left in the display window shows an up-arrow, and correspondingly a down-arrow when the amplitude decreases.

- i/ At the end of the measurements the VIBRAMETER should be turned off with the pushbutton  on the front panel. At the end of the day, it should be switched off with the power switch at the back of the VIBRAMETER.

CHAPTER 2. OPERATING INSTRUCTIONS

2.1 BEFORE MEASUREMENTS

- a/ The vibratory perception thresholds are determined according to a standardized procedure. Those measurements are conveniently made by a nurse or a technician, who will achieve good accuracy after demonstration and some practice. Although cooperation from the patient is required, practice has shown that reliable results are easily obtained on most neurological patients.
- b/ It is good practice to check that the pressure indicator properly balances when the pressure is applied, as described in chapter 1.3. In this way the VIBRAMETER is given a quick check.
- c/ The patient should be comfortably seated, or lying on a bed, with as few disturbing factors in the surroundings as possible. Relaxation of the test site (hand, foot, etc) should be provided by supporting it with a rice cushion (small sack of soft cloth, filled with ordinary house-hold rice), or sand bag.
- d/ As examiner You should be seated in a strain less position with comfortable access to, and visual contact with, both the test site and the VIBRAMETER . During measurement You should place the probe of the Vibrator perpendicularly to the test site, to provide smooth, painless, contact. Preferably there should be no tendons between vibrator and bone. This placement should be checked, during the measurement, to verify that the vibrator stays in the correct position.
- e/ Adjust the application pressure for center indication on the VIBRAMETER pressure indicator (small variations, like one or two indicator steps from the center, can be tolerated) and keep this application pressure during the measurements.

2.2 MEASURING PROCEDURE

- a/ Start with no vibration and tell the patient that “this is the feeling of the pressure from the vibrator”. Then increase the vibration amplitude to a supra threshold level and ask the patient if he can feel a vibration. When these two initial sensations are defined, and recognized, maybe after repeated trials, you have a coarse indication of the patients threshold, and the patient starts to be used to the measurement procedure.
- b/ Now you instruct the patient to tell you when the vibration first appears, the perception threshold (VPT), and when it disappears, the disappearance threshold (VDT). According to the classical methods of limits, the vibration threshold (VT) is then the average of VPT and VDT.
- c/ VT is usually recorded three times at the same test site, with the probe preferably removed between the measurements and reapplied at a nearby, or the same, location. If the three VT recordings differ in order of magnitude, further readings should be taken until three readings in the same range has been obtained. The average of these three VT recordings constitutes the final VT value.
- d/ Normal variation of successive readings at the same location is less than 10 %. Greater variation is seen in patients with elevated thresholds, and occasionally on tibia of healthy subjects. Deviating VT values may also appear if the patient mix the sensation of the application pressure and the vibratory stimulus, is distracted, receive irrelevant sensory stimuli, has muscle tension or sympathetic hyperactivity.

- e/** Long term variation can be considerably greater than 10 %. Any change in threshold has to be evaluated critically before it is taken as evidence of deterioration or improvement. For example, if a change is recorded only at one site, it may be irrelevant. If, on the other hand, a change is recorded at all sites, proximal as well as distal, an altered state of attention, or cooperation, should be considered.
- f/** Some subjects, especially patients with elevated thresholds, have difficulties in reporting VDT, which is more vague than VPT. Other patients adapt to a sustained vibration so that VDT is reported at about the same level of vibration as VPT. In these types of patients only VPT may be recorded. Goldberg et. al. has shown that using only VPT does not create a significant increase in the uncertainty of the perception threshold, compared to VT.
- g/** One of the large benefits of using the VIBRAMETER , is the possibility to compare the individual value with some form of norm. The norm may be obtained from the same patient, as when comparing the thresholds on the left and right side after some unilateral treatment, or it may be obtained from a “normal” group.
- h/** When comparing an individual vibratory threshold, with the mean of a group, there is a possibility to determine if the individual value statistically belongs to the group, or if it is different from the group. If the group is selected out of a normal, healthy, population, then there is a possibility to decide if the individual vibratory threshold is “normal”, or not.

CHAPTER 3. USE OF NORMAL MATERIAL AND TABLES

3.1 DESCRIPTION OF DIFFERENT TABLES

On the following pages are tables, obtained from a normal group of 110 healthy male volunteers, aged from 10 to 74 years, with no signs or symptoms of neurological diseases. The normal material was collected at an application pressure of 500 grams and at three standardized test sites:

TARSAL

- the dorsomedial aspect of the first metatarsal bone;

TIBIAL

- the flat surface of the proximal part of the tibia;

CARPAL

- the dorsum of the metacarpal bone of the index finger.

For further details of subjects and methods, see Goldberg and Lindblom (1979).

To use the tables first select if it is VT or VPT You want to refer to, then the table that corresponds to the point measured. Find the actual vibration threshold in the left column and follow this line until You are in the column representing the age of the patient, where You can read the deviation from the group. It is common practice to define a value as “different” from a group, if it deviates more than 2 standard deviations from the group. The area in the tables which represent vibration thresholds which are more than 2 standard deviations from the mean is marked by a shaded background.

Although the tables are simple to use, there are some words of precaution that are motivated:

- a/** Even if more than 95 % of the population should fall within the 2 standard deviation limit, there are still some normal persons that don't !
- b/** The normal group was collected in Stockholm, Sweden and consisted only of men. There may be regional as well as sex variations.
- c/** The technique used is of great importance for the reproducibility of the measurements. You need practice to have a low variability in the measurements.
- d/** Different routines in between investigators may introduce systematic errors, that could bias Your measurements when referred to this normal material.

There is only one way to make sure that You can use the normal tables, and that is to construct a normal material of Your own ! Of course it does not need to contain 110 subjects, but we strongly recommend that You start to use the VIBRAMETER by determining the vibratory thresholds of a number of “normals”, to obtain some practice and to check if Your determinations of vibratory thresholds appears to agree with the present normal material.

A study in Marburg, Germany, (prof. H. Fruhstorfer, unpublished material) conducted on an even larger population than for the present normal material, confirms the basic statistical properties of the normal group, and indicates that b/, above, may have less importance, and that c/ and d/ can be controlled.

In case You decide to evaluate a normal group of Your own, some information that may be of help are found in Chapter 5.

CHAPTER 4. NORMAL TABLES

4.1 SHORT DESCRIPTION

On the following pages are the normal tables, as obtained from the study of Goldberg and Lindblom (1979).

First are the tables for the VT and then the tables for the VPT.

The normal material is valid for an application pressure of 400 to 500 grams and is given for the three standardized test sites:

TARSAL

- the dorsomedial aspect of the first metatarsal bone;

TIBIAL

- the flat surface of the proximal part of the tibia;

CARPAL

- the dorsum of the metacarpal bone of the index finger.

4.2 CARPAL VT - Deviation from mean.

AMPL.	AGE										
	20	25	30	35	40	45	50	55	60	65	70
0.05	-1.9	-2.0	-2.1	-2.3	-2.4	-2.5	-2.7	-2.8	-2.9	-3.0	-3.2
0.10	-0.8	-0.9	-1.0	-1.1	-1.3	-1.4	-1.5	-1.7	-1.8	-1.9	-2.0
0.15	-0.1	-0.2	-0.4	-0.5	-0.6	-0.7	-0.9	-1.0	-1.1	-1.3	-1.4
0.20	0.4	0.2	0.1	-0.0	-0.1	-0.3	-0.4	-0.5	-0.7	-0.8	-0.9
0.25	0.7	0.6	0.5	0.4	0.2	0.1	-0.0	-0.2	-0.3	-0.4	-0.5
0.30	1.0	0.9	0.8	0.6	0.5	0.4	0.3	0.1	0.0	-0.1	-0.2
0.35	1.3	1.2	1.0	0.9	0.8	0.6	0.5	0.4	0.3	0.1	0.0
0.40	1.5	1.4	1.2	1.1	1.0	0.9	0.7	0.6	0.5	0.4	0.2
0.45	1.7	1.6	1.4	1.3	1.2	1.1	0.9	0.8	0.7	0.5	0.4
0.50	1.9	1.7	1.6	1.5	1.4	1.2	1.1	1.0	0.8	0.7	0.6
0.55	2.0	1.9	1.8	1.6	1.5	1.4	1.3	1.1	1.0	0.9	0.7
0.60	2.2	2.0	1.9	1.8	1.7	1.5	1.4	1.3	1.1	1.0	0.9
0.65	2.3	2.2	2.0	1.9	1.8	1.7	1.5	1.4	1.3	1.1	1.0
0.70	2.4	2.3	2.2	2.0	1.9	1.8	1.6	1.5	1.4	1.3	1.1
0.75	2.5	2.4	2.3	2.1	2.0	1.9	1.8	1.6	1.5	1.4	1.2
0.80	2.6	2.5	2.4	2.2	2.1	2.0	1.9	1.7	1.6	1.5	1.4
0.85	2.7	2.6	2.5	2.3	2.2	2.1	2.0	1.8	1.7	1.6	1.5
0.90	2.8	2.7	2.6	2.4	2.3	2.2	2.1	1.9	1.8	1.7	1.5
0.95	2.9	2.8	2.7	2.5	2.4	2.3	2.1	2.0	1.9	1.8	1.6
1.00	3.0	2.9	2.7	2.6	2.5	2.4	2.2	2.1	2.0	1.8	1.7
1.05	3.1	2.9	2.8	2.7	2.6	2.4	2.3	2.2	2.1	1.9	1.8
1.10	3.2	3.0	2.9	2.8	2.6	2.5	2.4	2.3	2.1	2.0	1.9
1.15	3.2	3.1	3.0	2.8	2.7	2.6	2.5	2.3	2.2	2.1	1.9
1.20	3.3	3.2	3.0	2.9	2.8	2.7	2.5	2.4	2.3	2.1	2.0
1.25	3.4	3.2	3.1	3.0	2.9	2.7	2.6	2.5	2.3	2.2	2.1

4.3 TIBIAL VT - Deviation from mean.

AMPL.	AGE										
	20	25	30	35	40	45	50	55	60	65	70
0.25	-0.2	-0.4	-0.7	-0.9	-1.2	-1.4	-1.7	-1.9	-2.1	-2.4	-2.6
0.50	0.8	0.5	0.3	0.0	-0.2	-0.4	-0.7	-0.9	-1.2	-1.4	-1.7
0.75	1.3	1.1	0.9	0.6	0.4	0.1	-0.1	-0.4	-0.6	-0.8	-1.1
1.00	1.7	1.5	1.3	1.0	0.8	0.5	0.3	0.0	-0.2	-0.4	-0.7
1.25	2.1	1.8	1.6	1.3	1.1	0.8	0.6	0.4	0.1	-0.1	-0.4
1.50	2.3	2.1	1.8	1.6	1.3	1.1	0.9	0.6	0.4	0.1	-0.1
1.75	2.5	2.3	2.0	1.8	1.6	1.3	1.1	0.8	0.6	0.3	0.1
2.00	2.7	2.5	2.2	2.0	1.7	1.5	1.3	1.0	0.8	0.5	0.3
2.25	2.9	2.6	2.4	2.2	1.9	1.7	1.4	1.2	0.9	0.7	0.5
2.50	3.0	2.8	2.5	2.3	2.1	1.8	1.6	1.3	1.1	0.8	0.6
2.75	3.2	2.9	2.7	2.4	2.2	2.0	1.7	1.5	1.2	1.0	0.7
3.00	3.3	3.0	2.8	2.6	2.3	2.1	1.8	1.6	1.3	1.1	0.9
3.25	3.4	3.2	2.9	2.7	2.4	2.2	1.9	1.7	1.5	1.2	1.0
3.50	3.5	3.3	3.0	2.8	2.5	2.3	2.0	1.8	1.6	1.3	1.1
3.75	3.6	3.4	3.1	2.9	2.6	2.4	2.1	1.9	1.7	1.4	1.2
4.00	3.7	3.4	3.2	3.0	2.7	2.5	2.2	2.0	1.7	1.5	1.3
4.25	3.8	3.5	3.3	3.0	2.8	2.6	2.3	2.1	1.8	1.6	1.3
4.50	3.9	3.6	3.4	3.1	2.9	2.6	2.4	2.2	1.9	1.7	1.4
5.00	4.0	3.8	3.5	3.3	3.0	2.8	2.5	2.3	2.1	1.8	1.6
5.50	4.1	3.9	3.7	3.4	3.2	2.9	2.7	2.4	2.2	2.0	1.7
6.00	4.3	4.0	3.8	3.5	3.3	3.0	2.8	2.6	2.3	2.1	1.8
6.50	4.4	4.1	3.9	3.6	3.4	3.2	2.9	2.7	2.4	2.2	1.9
7.00	5.4	4.2	4.0	3.7	3.5	3.3	3.0	2.8	2.5	2.3	2.1
7.5	4.6	4.3	4.1	3.8	3.6	3.4	3.11	2.9	2.6	2.4	2.1

4.4 TARSALE VT - Deviation from mean.

AMPL.	AGE										
	20	25	30	35	40	45	50	55	60	65	70
0.25	0.2	-0.1	-0.5	-0.9	-1.3	-1.7	-2.0	-2.4	-2.8	-3.2	-3.5
0.50	1.1	.07	0.4	-0.0	-0.4	-0.8	-1.2	-1.5	-1.9	-2.3	-2.7
0.75	1.6	1.2	0.9	0.5	0.1	-0.3	-0.6	-1.0	-1.4	-1.8	-2.2
1.00	2.0	1.6	1.2	0.9	0.5	0.1	-0.3	-0.7	-1.0	-1.4	-1.8
1.25	2.3	1.9	1.5	1.1	0.8	0.4	0.0	-0.4	-0.8	-1.1	-1.5
1.50	2.5	2.1	1.7	1.4	1.0	0.6	0.21	-0.1	-0.5	-0.9	-1.3
1.75	2.7	2.3	1.9	1.6	1.2	0.8	0.4	0.0	-0.4	-0.7	-1.1
2.00	2.9	2.5	2.1	1.7	1.4	1.0	0.6	0.2	-0.2	-0.5	-0.9
2.50	3.1	2.8	2.4	2.0	1.6	1.3	0.9	0.5	0.1	-0.3	-0.6
3.00	3.4	3.0	2.6	2.2	1.9	1.5	1.1	0.7	0.4	-0.0	-0.4
3.50	3.6	3.2	2.8	2.4	2.1	1.7	1.3	0.9	0.5	0.2	-0.2
4.00	3.7	3.4	3.0	2.6	2.2	1.8	1.5	1.1	0.7	0.3	-0.0
5.00	4.0	3.6	3.3	2.9	2.5	2.1	1.8	1.4	1.0	0.6	0.2
6.00	4.2	3.9	3.5	3.1	2.7	2.4	2.0	1.6	11.2	0.8	0.5
7.00	4.4	4.1	3.7	3.3	2.9	2.6	2.2	1.8	1.4	1.0	0.7
8.00	4.6	4.2	3.9	3.5	3.1	2.7	2.3	2.0	1.6	1.2	0.8
9.00	4.8	4.4	4.0	3.6	3.2	2.9	2.5	2.1	1.7	1.4	1.0
10.00	4.9	4.5	4.11	3.8	3.4	3.0	2.6	2.2	1.9	1.5	1.1
12.00	5.1	4.7	4.4	4.0	3.6	3.2	2.9	2.5	2.1	1.7	1.3
14.00	5.3	4.9	4.6	4.2	3.8	3.4	3.1	2.7	2.3	1.9	1.5
16.00	5.5	5.1	4.7	4.4	4.0	3.6	3.2	2.8	2.5	2.1	1.7
20.00	5.8	5.4	5.0	4.6	4.3	3.9	3.5	3.1	2.7	2.4	2.0
25.00	6.1	5.7	5.3	4.9	4.5	4.2	3.8	3.4	32.0	2.6	2.3

4.5 CARPAL VPT - Deviation from mean.

AMPL.	AGE										
	20	25	30	35	40	45	50	55	60	65	70
0.05	-2.4	-2.5	-2.7	-2.8	-3.0	-3.1	-3.3	-3.4	-3.6	-3.7	-3.9
0.10	-1.2	-1.3	-1.5	-1.6	-1.8	-1.9	-2.1	-2.2	-2.4	-2.6	-2.7
0.15	-0.5	-0.7	-0.8	-1.0	-1.1	-1.3	-1.4	-1.6	-1.7	-1.9	-2.0
0.20	-0.0	-0.2	-0.3	-0.5	-0.6	-0.8	-0.9	-1.1	-1.2	-1.4	-1.5
0.25	0.4	0.2	0.1	-0.1	-0.2	-0.4	-0.5	-0.7	-0.9	-1.0	-1.2
0.30	0.7	0.5	0.4	0.2	0.1	-0.1	-0.2	-0.4	-0.5	-0.7	-0.8
0.35	0.9	0.8	0.6	0.5	0.3	0.2	0.0	-0.1	-0.3	-0.4	-0.6
0.40	1.2	1.0	0.9	0.7	0.5	0.4	0.2	0.1	-0.1	-0.2	-0.4
0.45	1.4	1.2	1.1	0.9	0.7	0.6	0.4	0.3	0.1	-0.0	-0.2
0.50	1.5	1.4	1.2	1.1	0.9	0.8	0.6	0.5	0.3	0.2	0.0
0.55	1.7	1.5	1.4	1.2	1.1	0.9	0.8	0.6	0.5	0.3	0.2
0.60	1.8	1.7	1.5	1.4	1.2	1.1	0.9	0.8	0.6	0.5	0.3
0.65	2.0	1.8	1.7	1.5	1.4	1.2	1.1	0.9	0.8	0.6	0.5
0.70	2.1	2.0	1.8	1.6	1.5	1.3	1.2	1.0	0.9	0.7	0.6
0.75	2.2	2.1	1.9	1.8	1.6	1.5	1.3	1.2	1.0	0.9	0.7
0.80	2.3	2.2	2.0	1.9	1.7	1.6	1.4	1.3	1.1	1.0	0.8
0.85	2.4	2.3	2.1	2.0	1.8	1.7	1.5	1.4	1.2	1.1	0.9
0.90	2.5	2.4	2.2	2.1	1.9	1.8	1.6	1.5	1.3	1.2	1.0
0.95	2.6	2.5	2.3	2.2	2.0	1.9	1.7	1.6	1.4	1.3	1.1
1.00	2.7	2.6	2.4	2.2	2.1	1.9	1.8	1.6	1.5	1.3	1.2
1.05	2.8	2.6	2.5	2.3	2.2	2.0	1.9	1.7	1.6	1.4	1.3
1.10	2.9	2.7	2.6	2.4	2.3	2.1	2.0	1.8	1.7	1.5	1.3
1.15	2.9	2.8	2.6	2.5	2.3	2.2	2.0	1.9	1.7	1.6	1.4
1.20	3.0	2.9	2.7	2.6	2.4	2.3	2.1	2.0	1.8	1.6	1.5
1.25	3.1	2.9	2.8	2.6	2.5	2.3	2.2	2.0	1.9	1.7	1.6

4.6 TIBIAL VPT - Deviation from mean.

AMPL.	AGE										
	20	25	30	35	40	45	50	55	60	65	70
0.25	-0.5	-0.8	-1.0	-1.3	-1.5	-1.8	-2.0	-2.3	-2.5	-2.8	-3.0
0.50	0.5	0.2	-0.0	-0.3	-0.5	-0.8	-1.0	-1.3	-1.5	-1.8	-2.0
0.75	1.0	0.8	0.5	0.3	0.1	-0.2	-0.4	-0.7	-0.9	-1.2	-1.4
1.00	1.5	1.2	1.0	0.7	0.5	0.2	-0.0	-0.3	-0.5	-0.8	-1.0
1.25	1.8	1.5	1.3	1.0	0.8	0.5	0.3	0.0	-0.2	-0.4	-0.7
1.50	2.0	1.8	1.6	1.3	1.1	0.8	0.6	0.3	0.1	-0.2	-0.4
1.75	2.3	2.0	1.8	1.5	1.3	1.0	0.8	0.5	0.3	0.0	-0.2
2.00	2.5	2.2	2.0	1.7	1.5	1.2	1.0	0.7	0.5	0.2	-0.0
2.25	2.6	2.4	2.1	1.9	1.6	1.4	1.1	0.9	0.6	0.4	0.2
2.5	2.8	2.5	2.3	2.0	1.8	1.5	1.3	1.1	0.8	0.6	0.3
2.75	2.9	2.7	2.4	2.2	1.9	1.7	1.4	1.2	0.9	0.7	0.4
3.00	3.0	2.8	2.6	2.3	2.1	1.8	1.6	1.3	1.1	0.8	0.6
3.25	3.2	2.9	2.7	2.4	2.2	1.9	1.7	1.4	1.2	0.9	0.7
3.50	3.3	3.0	2.8	2.5	2.3	2.0	1.8	1.5	1.3	1.0	0.8
3.75	3.4	3.1	2.9	2.6	2.4	2.1	1.9	1.6	1.4	1.1	0.9
4.00	3.5	3.2	3.0	2.7	2.5	2.2	2.0	1.7	1.5	1.2	1.0
4.25	3.6	3.3	3.1	2.8	2.6	2.3	2.1	1.8	1.6	1.3	1.1
4.50	3.6	3.4	3.1	2.9	2.6	2.4	2.1	1.9	1.7	1.4	1.2
5.00	3.8	3.5	3.3	3.0	2.8	2.5	2.3	2.1	1.8	1.6	1.3
5.50	3.9	3.7	3.4	3.2	2.9	2.7	2.4	2.2	1.9	1.7	1.4
6.00	4.1	3.8	3.6	3.3	3.1	2.8	2.6	2.3	2.1	1.8	1.6
6.50	4.2	3.9	3.7	3.4	3.2	2.9	2.7	2.4	2.2	1.9	1.7
7.00	4.3	4.0	3.8	3.5	3.3	3.0	2.8	2.5	2.3	2.0	1.8
7.50	4.4	4.1	3.9	3.6	3.4	3.1	2.9	2.66	2.4	2.1	1.9

4.7 TARSALE VPT - Deviation from mean

AMPL.	AGE										
	20	25	30	35	40	45	50	55	60	65	70
0.25	-0.1	-0.5	-0.9	-1.2	-1.6	-2.0	-2.4	-2.8	-3.2	-3.5	-3.9
0.50	0.8	0.4	0.0	-0.3	-0.7	-1.1	-1.5	-1.9	-2.3	-2.6	-3.0
0.75	1.3	1.0	0.6	0.2	-0.2	-0.6	-1.0	-1.3	-1.7	-2.1	-2.5
1.00	1.7	1.3	0.9	0.6	0.2	-0.2	-0.6	-1.0	-1.4	-1.7	-2.1
1.25	2.0	11.6	1.2	0.8	0.5	0.1	-0.3	-0.7	-1.1	-1.4	-1.8
1.50	2.2	1.9	1.5	1.1	0.7	0.3	-0.1	-0.4	-0.8	-1.2	-1.6
1.75	2.4	2.1	1.7	1.3	0.9	0.5	0.1	-0.2	-0.6	-1.0	-1.4
2.00	2.6	2.2	1.8	1.5	1.1	0.7	0.3	-0.1	-0.5	-0.8	-1.2
2.50	2.9	2.5	2.1	1.7	1.4	1.0	0.6	0.2	-0.2	-0.6	-0.9
3.00	3.1	2.7	2.4	2.0	1.6	1.2	0.8	0.4	0.1	-0.3	-0.7
3.50	3.3	2.9	2.6	2.2	1.8	1.4	1.0	0.6	0.3	-0.1	-0.5
4.00	3.5	3.1	2.7	2.4	2.0	1.6	1.2	0.8	0.4	0.1	-0.3
5.00	3.8	3.4	3.0	2.6	2.3	1.9	1.5	1.1	0.7	0.3	-0.0
6.00	4.0	3.6	3.3	2.9	2.5	2.1	1.7	1.3	1.0	0.6	0.2
7.00	4.2	3.8	3.5	3.2	2.7	2.3	1.9	1.5	1.2	0.8	0.4
8.00	4.4	4.0	3.6	3.3	2.9	2.5	2.1	1.7	1.3	1.0	0.6
9.00	4.6	4.2	3.8	3.4	3.0	2.6	2.3	1.9	1.5	1.1	0.7
10.00	4.7	4.3	3.9	3.5	3.2	2.8	2.4	2.0	2.6	1.2	0.9
12.00	4.9	4.5	4.2	3.8	3.4	3.0	2.6	2.2	1.9	1.5	1.1
14.00	5.1	4.7	4.4	4.0	3.6	3.2	2.8	2.4	2.1	1.7	1.3
16.00	5.3	4.9	4.5	4.2	3.8	3.4	3.0	2.6	2.2	1.9	1.5
20.00	5.6	5.2	4.8	4.4	4.1	3.7	3.3	2.9	2.5	2.1	1.8
25.00	5.9	5.5	5.1	4.7	4.3	4.0	3.6	3.2	2.8	2.4	2.0

CHAPTER 5. CONSTRUCTION OF NORMAL TABLES

5.1 STATISTICAL PROCEDURES

The basic data used in computing the normal tables is the statistical properties of the normal group. It has been shown (Goldberg and Lindblom, 1979) that the regression line between the logarithm of the VT, or VPT, and age of patient gives a good fit to the experimental data. If You want to find the statistical properties of Your normal group, then You should find the coefficients, a and b, in the equation:

$$\log(VT) = a + b \cdot AGE$$

using a standard program for linear regression (as found in many modern pocket calculators). The program will most likely also give You the s_{yx} , the estimate of the residual variation.

The interpretation if these coefficients are simple:

- a: logarithm of the VT at AGE = 0 (crossing of y-axis)
- b: coefficient of relation between AGE and log(VT)
- s: standard deviation around the normal regression line

For the present normal material these coefficients are:

	CA. VT	TI. VT	TA. VT	CA. VPT	TI. VPT	TA. VPT
a	-0.933	-0.839	-1.204	-0.851	-0.737	-1.087
b	0.0068	0.015	0.026	0.0078	0.0149	0.0257
s	0.266	0.309	0.344	0.257	0.300	0.335

The coefficients given above has been used to construct the normal tables, using the relation:

$$N(AGE, VT) = (\log(VT) - b \cdot AGE - a) / s$$

CHAPTER 6. MEDICAL BACKGROUND

6.1 DIFFERENT DISEASES

The function of the human neuronal system can be affected in many different cases. Neuropathies (polyneuropathies) may be found in patients with diabetes, in workers in neurotoxic industrial environments, and in disorders of metabolic, toxic or other origin.

In polyneuropathies the sensory system seems to be affected before the motor system. As few people have absolute references for their sensory sensations, this creates a situation where a gradual change in say taste function, or vibratory perception threshold, may as well pass unnoticed. The person struck by the neuropathia may not recognize the symptoms, until they finally obtain mobility disorders.

When suspecting a case of neuropathy, it is thus of great importance to observe the function of the sensory system, using different types of stimuli.

6.2 DETERMINATION OF VIBRATION SENSE

Determination of the vibration sense is one of the most frequent neurological tests for the sensory system. With a tuning fork, the ability to detect a vibrating object is determined. Although the test is simple to perform, the tuning fork only provides a rather coarse indication of the vibration sense, as well as it tells little, or nothing, of the progress of a disease. In between investigators and between different times of investigation there may also be large variations.

6.3 THE MEASURING INSTRUMENT

An instrument that measures the vibration perception threshold, providing an objective indicator of the function of this part of the sensory system, would thus most likely give way for a better diagnosis in suspected cases of neuropathy. By providing a graded scale for the vibration perception threshold, it may also be extremely useful to follow a patient during a long treatment, to be able to have an objective measure of the effect of the therapy, or a possibility to detect unwanted side-effects.

The vibratory perception threshold can be interpreted as an index of the function of the sensory myelinated nerve, assuming that the peripheral receptors are normal, or, reversing, assuming that the myelinated nerve is normal, as an index of the function of the peripheral receptors.

CHAPTER 7. GENERAL DESCRIPTION OF VIBRAMETRY

7.1 DEVELOPMENT OF THE TECHNIQUE

A convenient technique for bedside or ambulatory measurement of the vibration sense has been developed by M. Goldberg and U. Lindblom (1979). This technique has so far been applied in the study of a large reference group of healthy subjects of various ages, and in the clinical examination and diagnosis of various cases of polyneuropathies, mononeuropathies and certain cases with spinal or cerebral lesions. The data from the reference group are available in the form of tables for different standardized test locations and age groups, for easy comparison with individual results. A general survey of the applications of vibrametry may include:

- 1:** To confirm or exclude impairment of vibration sensibility that has been suspected in screening examination with the tuning fork.
- 2:** Early diagnosis of polyneuropathies of metabolic, toxic or other origin.
- 3:** Examination of selected populations, for instance of patients with diabetes, or of workers in a neurotoxic industrial environment.
- 4:** Monitoring the course of a disease, for instance a progressive lesion, or for evaluation of treatment, by repeated examinations of the same patient.
- 5:** Research projects with studies on perception thresholds and intensity functions of the vibratory sensation.

7.2 THE VIBRAMETER

A special instrument, the VIBRAMETER has been developed by SBMEDIC Electronics for this technique. The VIBRAMETER consists of an electromagnetic stimulator and an electronic unit. During measurement, the stimulator, which vibrates with twice the mains frequency, is held against the skin of the patient. The application pressure is automatically monitored and compared to a reference, the difference being displayed and used to manually correct the application pressure. By means of a transducer in the stimulator, the vibration amplitude is measured directly at the stimulation site, and presented in micrometers peak to peak on a calibrated digital display. Special consideration has been paid to the ergonomic design of the instrument. It is easy to handle and easy to clean with common sterilizing solutions.

CHAPTER 8. TECHNICAL DESCRIPTION

8.1 FUNCTION

We assume that the reader is familiar with the operation of the VIBRAMETER, if not first study chapter 2.

- a/** The basic function of the VIBRAMETER is to provide a source for vibratory stimuli, whose amplitude can be accurately determined.
- b/** To generate the vibration, a hand-held vibrator is used, which is basically an unpolarized electromagnet that vibrates at twice the frequency of the applied electrical signal. Due to mechanical tuning optimal vibration amplitude is obtained for vibration at frequencies of 100 to 120 Hz.
- c/** The vibrator is powered from a low voltage (24V AC) power amplifier with high isolation between the mains supply and the vibrator. The input signal to this amplifier is a sinusoidal signal which is phase locked to the mains supply and has an amplitude that can be controlled by four push-buttons on the front panel of the control unit and/or a continuous thumb wheel control. At power ON the amplitude is reset to zero.
- d/** In the vibrator an electro-optical detection system determines the vibration amplitude and the application pressure of the vibrator probe.
- e/** The detector signals are processed in, and displayed on, the control unit, where the vibration amplitude is displayed on a 3 and 3/4 digit digital display and the application pressure on a “thermometer” scale.
- f/** A reference system for the application pressure gives a high sensitivity to the thermometer scale by displaying only the deviations around a small portion of the reference. From the front panel controls this reference can be set to any predetermined value within the range of the instrument. When the vibrator is applied at the reference pressure, the thermometer scale displays a mid-scale reading.

CHAPTER 9. TECHNICAL DATA

FUNCTIONAL:

Stimuli	Frequency:	100/120 Hz (2 * mains freq.)
	Measurement:	Range 1: 0 to 39.99 micron Range 2: 0 to 399.9 micron (1 micron = 1/1000 millimeter)
	Cal. uncertainty:	+/- (5% of reading + 5 dig.)

ELECTRICAL:

Power Requirements	Voltage:	AC 115 to 125 V +/- 10% AC 230 to 250 V +/- 10%
	Fuse:	at 115 to 125 V: 320mA slow blow at 230 to 250 V: 160mA slow blow
	Power Consumption:	30 watt.

PHYSICAL:

Weight	Instrument, as used:	5.5 kg
	Instrument, shipped:	6 kg
	Stimulator:	0.65 kg
Size	Instrument, width:	300 mm
	Instrument, depth:	270 mm
	Instrument, height:	95 mm
	(incl. stimulator):	145 mm
	Shipped, width:	440 mm
	Shipped, depth:	330 mm
	Shipped, height:	210 mm
	Shipped, volume:	0.030 m ³
Temp	Environmental temp.:	+15°C - +30°C (non condensing)

CHAPTER 10. SERVICE AND REPAIR

10.1 DURING WARRANTY

- a/ During the time the warranty is in effect, the VIBRAMETER can be returned to SBMEDIC Electronics for a free calibration and service inspection after the first year. This service is provided free of charge, the only requests is that the owner ship the VIBRAMETER on his expense to SBMEDIC Electronics, or our representative, and that the VIBRAMETER is sent in the original packaging material and box. It will normally be returned within a week, at the owners expense.
- b/ After the warranty period, this calibration and service inspection will be provided for a nominal fee.
- c/ If the VIBRAMETER needs service, outside of these inspections, it will either be provided as part of the normal warranty, or if outside the warranty period, at a nominal cost.

10.2 CALIBRATION

Normally there are no user serviceable parts inside the VIBRAMETER. All calibration test points are collected to a multipin connector, which together with all trim points are accessible at the rear of the instrument. For service outside the warranty period, the qualified user may obtain a calibration test set, including an accelerometer based calibrator for absolute calibration of the vibration amplitude.

10.3 WARRANTY

This is to certify that the VIBRAMETER have a warranty period of 1 (one) year, counted from the date of delivery, provided that a copy of this page is returned to SBMEDIC Electronics, or our representative, within 1 (one) month of the delivery with the proper information for registration of the owner given below.

Our liability, according to this warranty, shall apply only to defects that appear under the conditions of operation provided for by us and under proper use. In particular it does not cover defects arising from faulty maintenance or from any alterations carried out without our consent in writing.

In order to be able to quote this warranty, the owner shall without delay notify us of any defect that have appeared and await transport instructions before returning the VIBRAMETER to us for repair.

If, after examination of the VIBRAMETER, the warranty claim proves to be justified, the VIBRAMETER will be repaired and returned to the owner as soon as possible (normally within a week) and at our expense. By doing so we shall be deemed to have fulfilled all our obligations under this warranty.

The warranty is given to the original owner, and has a provision that the VIBRAMETER remains with the original owner. However, based on our decision, the warranty can also be valid if the VIBRAMETER is rented out, sold or transferred to another person or organisation, provided that we receive a written request for transfer of the warranty.

CHAPTER 11. INFORMATION ON RECYCLING OF ELECTRICAL EQUIPMENT



NOTE! DO NOT DISCARD THIS PRODUCT IN THE TRASH!

Used electrical and electronic equipment must be treated in accordance with applicable environmental laws and recycling regulations.



11.1 EU-countries

Under current EU rules, all have the opportunity to submit electrical equipment for recycling. This equipment contains batteries that must first be removed and handled in accordance with local environmental regulations.

By handling the product in accordance with these regulations, it will be disposed of and recycled in the appropriate manner, thus preventing potential adverse health and environmental effects.

If the product should be discarded:

Contact SBMEDIC Electronics or its distributors for information on how to go about returning the product. It may be a charge for transportation and recycling. Small products (in the case of a few) may be returned to local recycling facilities.

11.2 Countries outside the EU

Please contact your local authorities and ask for the correct method of disposal.